

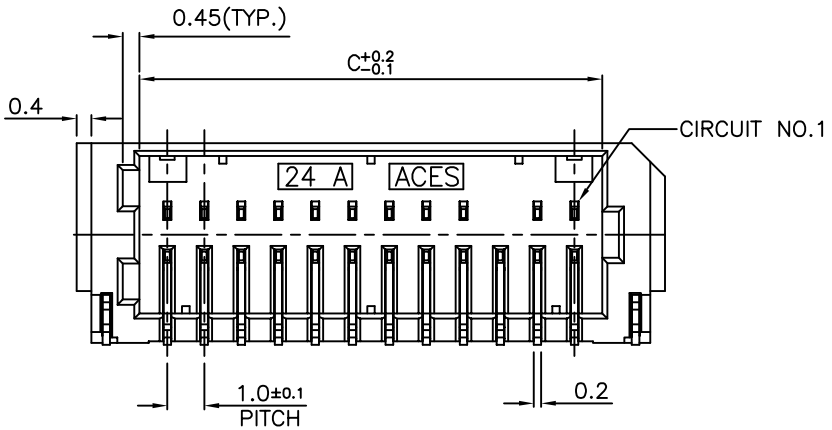

- NOTES:
- MATERIAL:
 - HOUSING: THERMOPLASTIC, HIGH TEMP., UL94V-0.
 - CONTACT: COPPER ALLOY
 - FITTING NAIL: COPPER ALLOY
 - FINISH:
 - CONTACT:
 - UNDERPLATING: 50~100u" NICKEL OVERALL.
 - FINISH: 15U" GOLD ON CONTACT AREA, GOLD FLASH ON SOLDER AREA
 - FITTING NAIL:
 - UNDERPLATING: 50~100u" NICKEL OVERALL.
 - FINISH: 80U" MIN MATTE TIN
 - REFLOW SOLDER CAPABLE TO 260°C PER ACES SPEC.
 - SPEC. PLS. REFER TO PS-50246-xxxx-xxx
 - PACKAGE PLS. REFER TO 51384-xxxx-xx-TRP
 - "Halogen Free" product: PART NUMBER

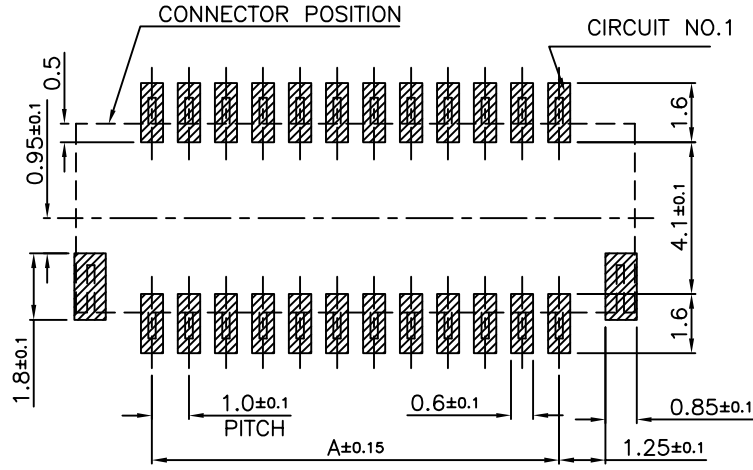

PCB PATTERN LAYOUT

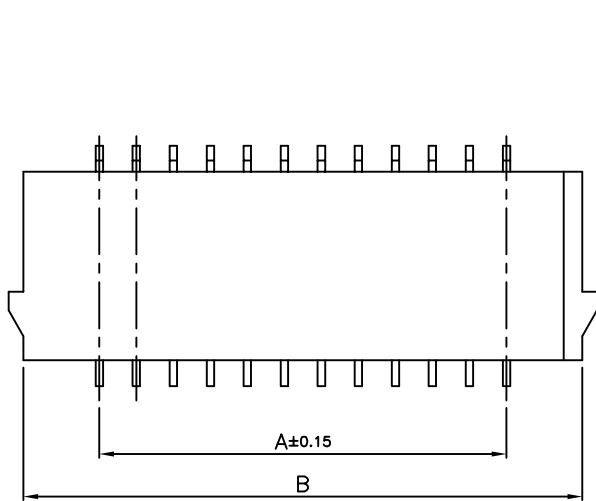
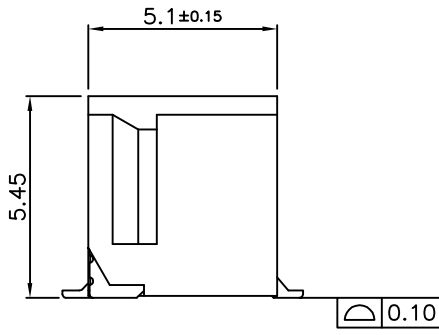

P/N LEGEND

51384-XXX X X-XXX

NO OF CKT
PACKING
0:TAPE REEL

XXX	MATERIAL&COLOR	HOUSING TYPE
001	HF-&BLACK	WITH LOCK

Plating
C:15u" Gold on contact area
(Lead Free)

CKT	Dim A	Dim B	Dim C
24	11.0	15.1	12.5

QUALITY SYMBOLS MAJOR CRITICAL GENERAL TOLERANCES (UNLESS SPECIFIED) X ±0.5 .X ±0.25 .XX ±0.15 .XXX ±0.1 ANGLES ±2°	DRAWN BY Chai,Yunhe DATE 18/09/07		
	CHECKED BY BRAVE DATE 18/09/07		TITLE 1.0mm WTB WAFER SMT R/A D/R TYPE
	APPROVED BY BRAVE DATE 18/09/07		SIZE A4 DWG NO. 51384-XXXXX-XXX
	UNITS mm SCALE 1:1		 SHEET NO. 1 OF 1 REV O PART NO. SEE NOTES